



WR-WL-OR

INDEX

1.0 GENERAL INFORMATION	GENERAL INFORMATION
1.1 LIST OF ATTACHED DOCUMENTS	
1.2 WARNINGS	
1.3 HANDLING AND STORAGE STORAGE HANDLING AND TRANSPORTATION	
1.4 IDENTIFICATION AND TECHNICAL DATA LABELS MOUNTED ON THE MACHINE LEVEL OF PROTECTION PRINCIPLE OF OPERATION CONTROL AND SAFETY DEVICES NOTE FOR WATER CONDENSED CHILLERS NOTE FOR OIL CHILLERS SIZE OF CHILLERS TECHNICAL DATA CORRECTION FACTORS TABLE PREVALENCE OF THE STANDARD PUMPS	
1.5 INTENDED AND UNINTENDED USE	
1.6 SAFETY	
1.7 RESIDUAL RISK	
2.0 INSTALLATION AND CONNECTIONS	INSTALLATION AND CONNECTIONS
2.1 GENERAL INFORMATION	
2.2 HYDRAULIC CONNECTIONS	
2.3 ELECTRICAL CONNECTIONS	
2.4 OPERATIONS WORK CONDITIONS TABLE WATER QUALITY TABLE NOTE FOR OIL CHILLERS	
3.0 ORDINARY MAINTENANCE	CONTROLS AND MAINTENANCE
3.1 SPECIAL MAINTENANCE	
3.2 COOLANT LEAKS CHECK	
3.3 SEARCHING FOR DEFECTS	
3.4 DISMANTLING AND DISPOSAL	
4.0 GENERAL WARRANTY CONDITIONS	GUARANTEE AND DELIVERY
4.1 DELIVERY	

1.0 GENERAL INFORMATION

This manual contains all the chiller installation, use and maintenance regulations, highlighting the related risks and dangers.

It was expressly designed to allow its staff to use it in a safe and secure manner. Read all the information therein carefully and be careful of the regulations marked with a symbol on the side. If not observed, they can cause damages to things, people, the environment and the chiller.



The manufacturer is not liable for any improper use of the chiller, for unauthorized changes and for not following the instructions contained in this manual.



The manual must be kept by the contractor and made available to the staff in charge of installing, running and maintaining the chiller.

1.1 LIST OF ATTACHED DOCUMENTS

List of documents provided with the chiller:

- Manual Part II
- Thermostat Manual and Configuration Chart
- Pump Manual
- Manual of Various Options (if requested by the client)

1.2 WARNINGS

The chiller was designed and built for professional use based on the current regulations (see the declaration of conformity in the Manual Part II).

The chiller is built with quality materials that underwent laboratory exams to verify its reliability and safety. It was inspected and put under warranty.



This manual is intended for the following professionals:

INSTALLER is required to verify the correct chiller installation based on the workplace safety regulations and the instructions contained in this manual.

OPERATOR (or user) is required to know all the workplace safety regulations, the instructions contained in this manual for its correct use and the ordinary maintenance of the chiller.

MAINTENANCE TECHNICIAN (or assistance technician) authorised by the chiller manufacturer for technical assistance, special maintenance and repairs.

Qualified staff means those professional figures who, given their training, education and experience as well as their specific knowledge of the workplace safety and accident prevention regulations, are authorised by the safety manager to perform the aforementioned activities.

	DANGER	SITUATIONS WHERE THERE IS A RISK OF ACCIDENT FOR THE OPERATOR AND THE RISK OF DAMAGE TO THE CHILLER
	ATTENTION	INFORMATION OR WARNING TO BE CAREFUL WHEN COMPLETING A PROCEDURE OR COMMAND
	INFORMATION	IMPORTANT INFORMATION

1.3 ACCEPTANCE, HANDLING AND STORAGE



ATTENTION The chiller must be transported and moved without liquid(s) in the tank(s) (only for models with a tank).

STORAGE

The chillers are packaged using standard packaging (unless otherwise agreed).

Loading and unloading must be done indoors.

Standard packaging does not protect the chiller from rain and inclement weather

Standard packaging is not suitable for transportation by boat

Standard packaging is not suitable for transportation by air

The environmental conditions for storage are the following:

-min ambient temperature -10°C for R134a/ R407C/ R404A/ R410A

-max ambient temperature $+60^{\circ}\text{C}$ for R134a

-max ambient temperature $+50^{\circ}\text{C}$ for R407C/R404A

-max ambient temperature $+45^{\circ}\text{C}$ for R410A

- max humidity UR 90%

HANDLING AND TRANSPORTATION



The chiller must be lifted safely without inclining it and laying it on its side using the appropriate equipment with the following characteristics:

-adequate capacity to lift the load

-the load must be balanced to avoid impact

-do not do any brusque and/or violent movements

-do not place other objects on the chiller

Examples:

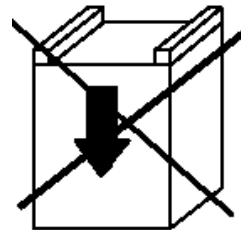
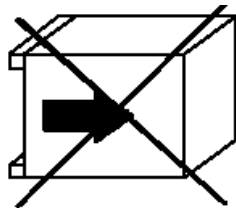
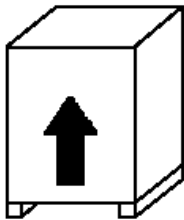

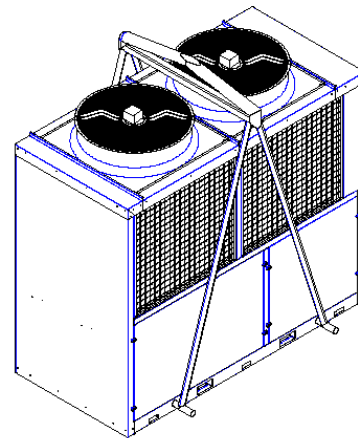
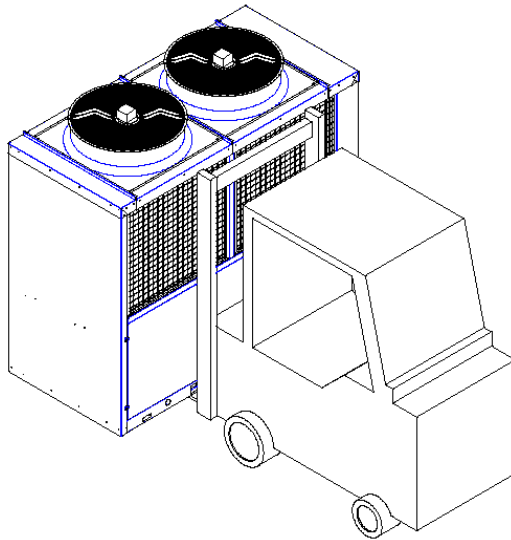

1.4 IDENTIFICATION AND TECHNICAL DATA

The chiller is identified with a technical data label that includes the following information:

Via E. Torrioni, 2 37067 Valdagno sul Mincio (VR) I Phone: 0445 8931900 Fax: 0445 8931035	
0035	
REFRIGERATORE DI LIQUIDO - LIQUID COOLER - KUHLANLAGE - REFRIGERISSEUR DE LIQUIDE	
MODELLO - MODEL - TYP - MODELE	WLAD842207ZA50 5018A
SERIE - SERIES - SERIE - SERIE	N90005411S
ORDINE - ORDER - ORDER - COMMANDER	2110005110
DATA - DATE - DATUM - DATE	13/07/11
Tensione nominale - Rated voltage - Nennspannung - Tension nominale	400/500 V
Avviamento/marcia - Starting/run current - Anlaufstrom/Nennstrom - Démarrage/marche	17441,6 A
Resa nom. - Cooling cap. - Kälteleistung - Puissance nominale	61 kW (W20L32)
Potenza Assorbita - Input power - Leistungsaufnahme - Puissance absorbée	23,3 kW (W20L32)
Carica gas - Filling capacity - Füllmenge - Charge de gaz	9,6 kg
Refrigerante tipo - Refrigerant type - Kältemittel - Refrigerant type	R407C
Peso - Weight - Gewicht - Poids	700 kg
TSS (Max temp. Di stoccaggio - Max Storage temp. - Max Lagertemperatur - Temp. Max d'emmagasine)	60 °C
TS MAX (Refrigerante - Refrigerant - Kältemittel - Refrigerant)	86 °C
TS MIN (Refrigerante - Refrigerant - Kältemittel - Refrigerant)	-10 °C
PS HP (Max pressione ammissibile HP - Max allowable pressure HP - Max zulässiger Druck HP - Pression maximum admissible HP)	28,6 bar
PS LP (Max pressione ammissibile LP - Max allowable pressure LP - Max zulässiger Druck LP - Pression maximum admissible LP)	20 bar
CAT PED	II
Modulo valutazione - Evaluation Module - Bewertungsverfahren - Procédure d'évaluation	A1
Contiene gas fluorurati ad effetto serra disciplinati dal protocollo di Kyoto - Device containing HFC fluids causing greenhouse effect regulated by Kyoto protocol - Das Gerät enthält wie vom Kyoto-Protokoll geregelte Fluorkohlenwasserstoffe Treibhausgasen - Dispositif contenant fluides HFC à effet de serre disciplinés par le protocole de Kyoto	
MADE IN ITALY	

TYPE OF LIQUID TO CHILL:

Ex. **WRA3541N07C000** water (water solutions + additives)

Ex. **WLAD842207C000** water (water solutions + additives)

Ex. **ORA9542207C000** oil (see note for oil chillers in chap. 2.4 Operations)

LABELS MOUNTED ON THE MACHINE:

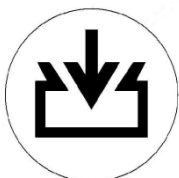

FILING
TANK



MOVING PARTS HAZARD

UNLOADING
TANK

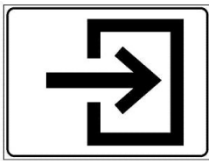

INCOMING
FLUID
CHILLER

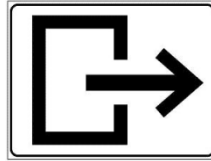

OUTGOING
FLUID
CHILLER

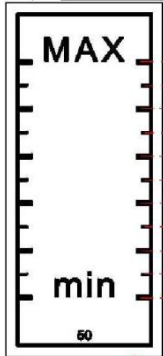

TANK LEVEL



ROTATION DIRECTION
ENGINES



RISK OF TENSION



ATTENTION! HOT SURFACES

LEVEL OF PROTECTION

SERIES	MODELS	INSTALLATION	POWER	CONTROL PANEL PROTECTION (mounted on the machine)	ENGINE PROTECTION (from the external environment)
WLA Compact	ALL	INDOOR	230/1/50-60	IP 21	IP 21
WRA Vertical + ORA O-FLOW	WRA 13-20-35-45-58-70-85 ORA 20-34-43-58-70	INDOOR	230/1/50-60 400/3/50 460/3/60	IP 21	IP 21
WRA Vertical + ORA O-FLOW	WRA 95-A3-A6-A8-B4-B8-C2-C8-D8 ORA 95-A3-A6	OUTDOOR	400/3/50 460/3/60	IP54	IP 44
WLA Precision	ALL	OUTDOOR	400/3/50 460/3/60	IP54	IP 44
WLA Precision R410A	ALL	OUTDOOR	400/3/50 460/3/60	IP54	IP 44

The IP (International Protection) code is a convention defined in EN 60529 standard (implemented by CEI as CEI 70-1 standard) to identify the degree of protection provided by enclosures for electrical and electronic equipment against the penetration of external agents in solid or liquid form.

PRINCIPLE OF OPERATION

The chiller is designed to chill liquids and is suitable for industrial environments. Its use allows the temperature of the liquid to chill to be controlled.

The principle of operation is the following:

The compressor compresses coolants, bringing it to a high pressure and temperature; the gas passing through the condenser is chilled and liquefied, releasing heat into the environment. Pushed toward the filling system or valve, the liquid gas drops in pressure which helps its evaporation, which occurs in the evaporator, in contact with the liquid coming from the catchments that is chilled.

CONTROL AND SAFETY DEVICES

- Safety pressure switch: It stops the compressor operation when the internal pressure of the circuit exceeds the calibration level - (High pressure switch)
- Safety valve (when installed): It vents the internal pressure of the circuit to the atmosphere if there would be an abnormal increase in pressure with the equipment in operation or switched off

NOTE FOR WATER CONDENSED CHILLERS

For chillers WRW, WLW AND ORW with a water condenser in the heat exchanger, follow the following instructions:

Condensation condenser temperature water entering to the exchanger operation limits. Min/Max 10-30°C.

Recommended filtering level μm 500.

The minimum capacity is suggested in the technical chart attached to the machine and varies to vary the required chiller capacity or for any special client requests, which are occasionally analyzed by the technical office.

The adjustment of the water pressure valve on the water side is done when it is inspected in the plant. For any problems/questions, contact aftersales.

A short discussion about the heat exchangers used to condense the water chiller:

Load loss

The load loss values that are found in the heat exchangers can be estimated at a minimum of 0.1 bar and a maximum of 0.5 bar.

Dirtiness and Corrosion

To increase the efficiency of the exchangers, reduce, or avoid, build-ups due to materials in the liquids, for example, mud, sand, etc, which often occurs in exchangers powered by rainwater, cooling towers, river water, lake water, etc. They are not suited for salt water.

Dirtying due to carbonate would seem to be different since, as is known, they cannot be influenced by the operation of the exchanger's temperature: precipitation starts when the water that is contained therein exceeds the threshold of 45°C.

The heat exchangers are clean with suitable fluids for this purpose. Problems of corrosion are limited given the specific resistance of the materials used for construction.

SIZE OF WLA COMPACT

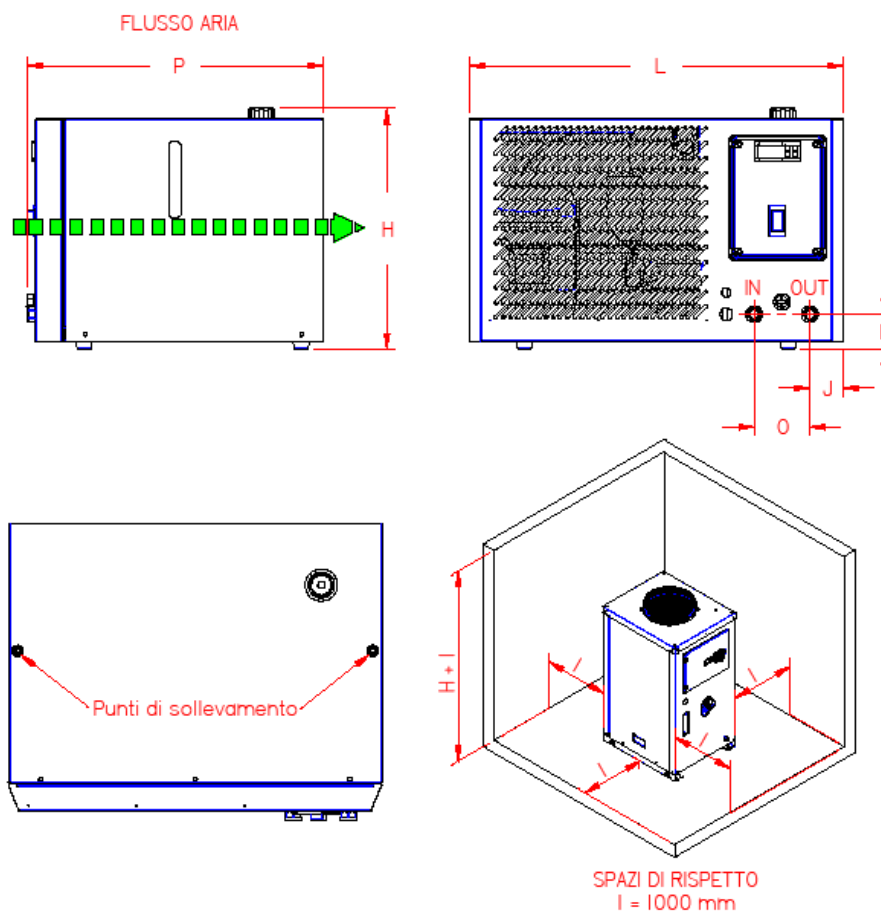

MOD.	(mm)							IN/OUT UNI ISO228
	L	P	H	K	J	O		
WLA 14-20	604	480	388	56	54	90	½ "G	
WLA 28-41-45	807	494	504	70	54	90	½ "G	

WRA VERTICAL + ORA O-FLOW SIZE

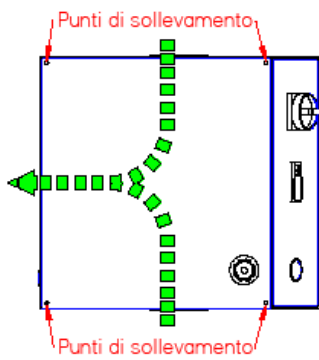
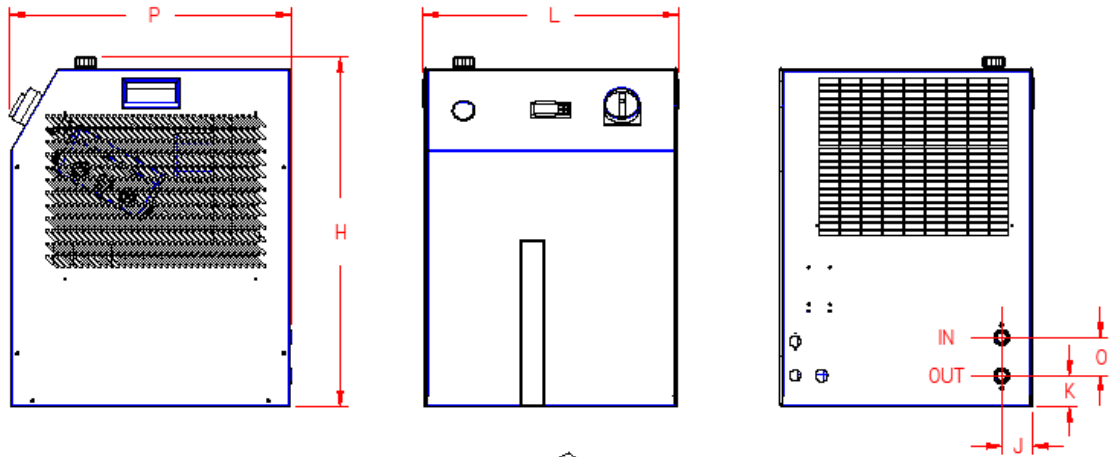

FLUSSO ARIA

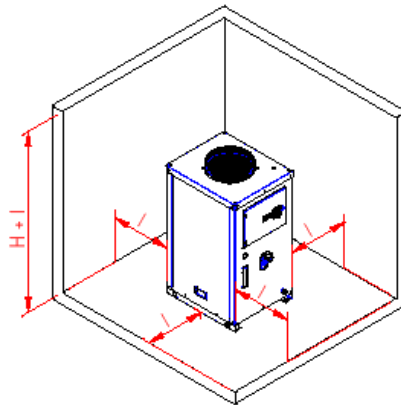

 SPAZI DI RISPETTO
I = 1000 mm

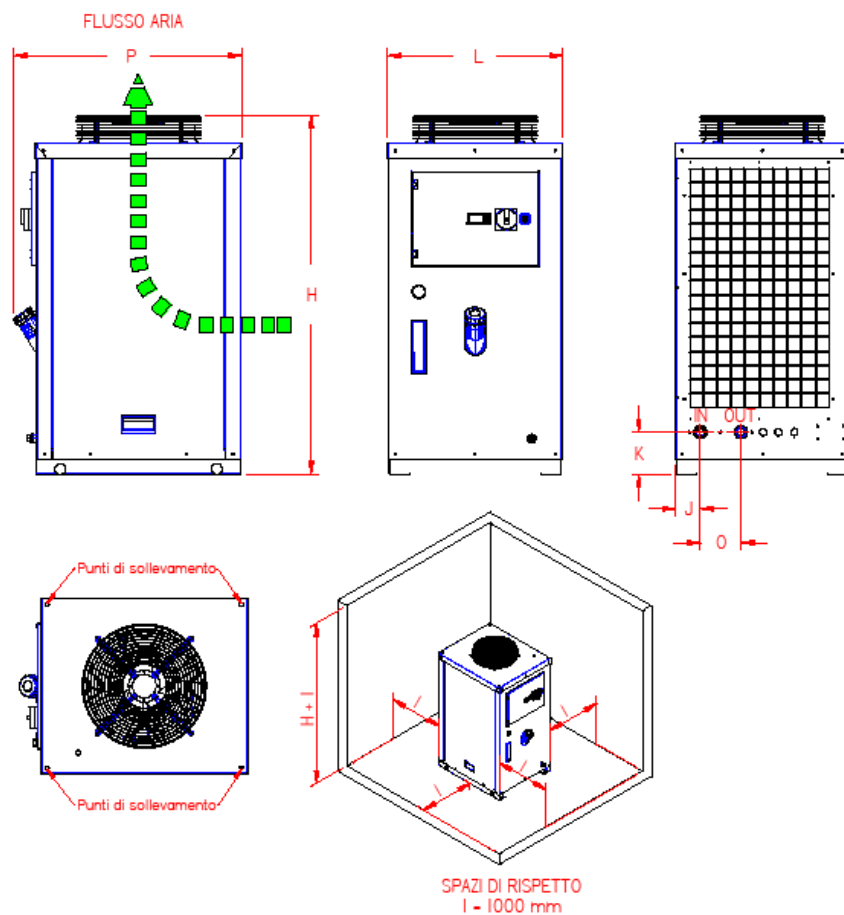
MOD.	(mm)							IN/OUT
	L	P	H	K	J	O	UNI ISO228	
WRA 13-20	480	525	686	87	59	72	½ "G	

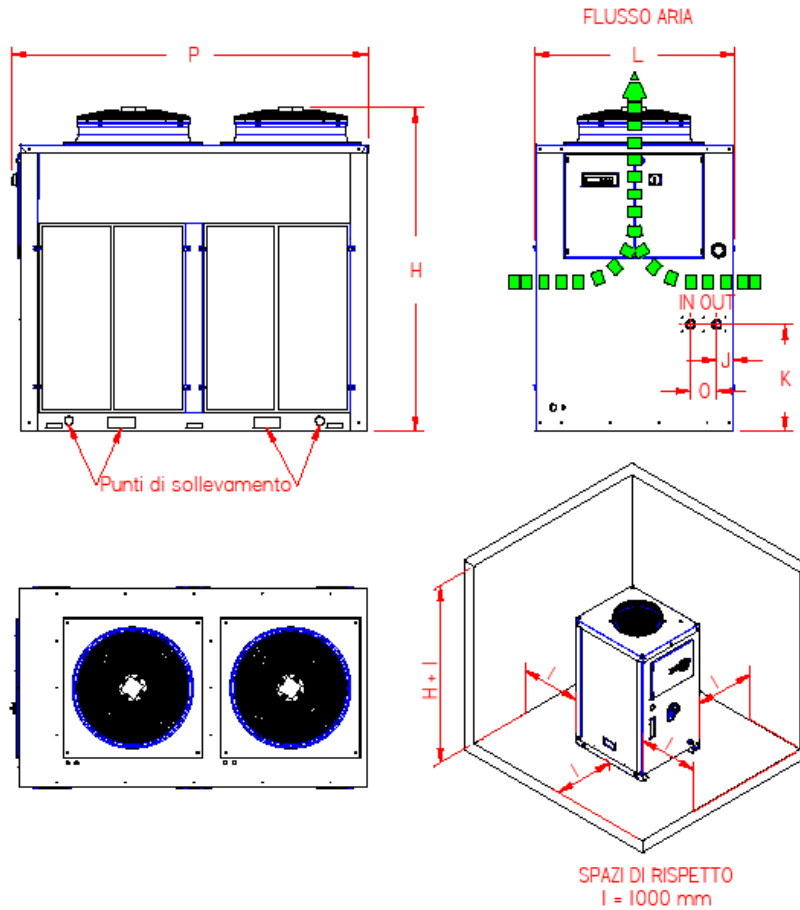

MOD.	(mm)							IN/OUT UNI ISO228
	L	P	H	K	J	O		
ORA 20	420	580	720	90	54	72	1/2" G	
WRA 35-45-58-70 ORA 34-43-58-70	570	740	1146	135	85	130	3/4" G	
WRA 85	570	740	1220	135	85	130	3/4" G	
WRA 95-A3-A6 ORA 95-A3-A6	735	926	1500	142	121	130	1" G	
WRA A8-B4-B8-C2	900	1200	1930	165	170	150	1 1/4" G	
WRA C8-D8	1250	1250	2000	190	170	150	1 1/2" G	

SIZE OF WLA PRECISION



MOD.	(mm)							IN/OUT UNI ISO228
	L	P	H	K	J	O		
WLA B8-C2	700	1650	1450	615	98	150	1 ¼"G	
WLA C8-D8	1140	2000	1820	615	98	150	1 ½"G	
WLA G2-H8	1140	2000	1820	615	98	150	1 ½"G	

SIZE OF WLA PRECISION R410A

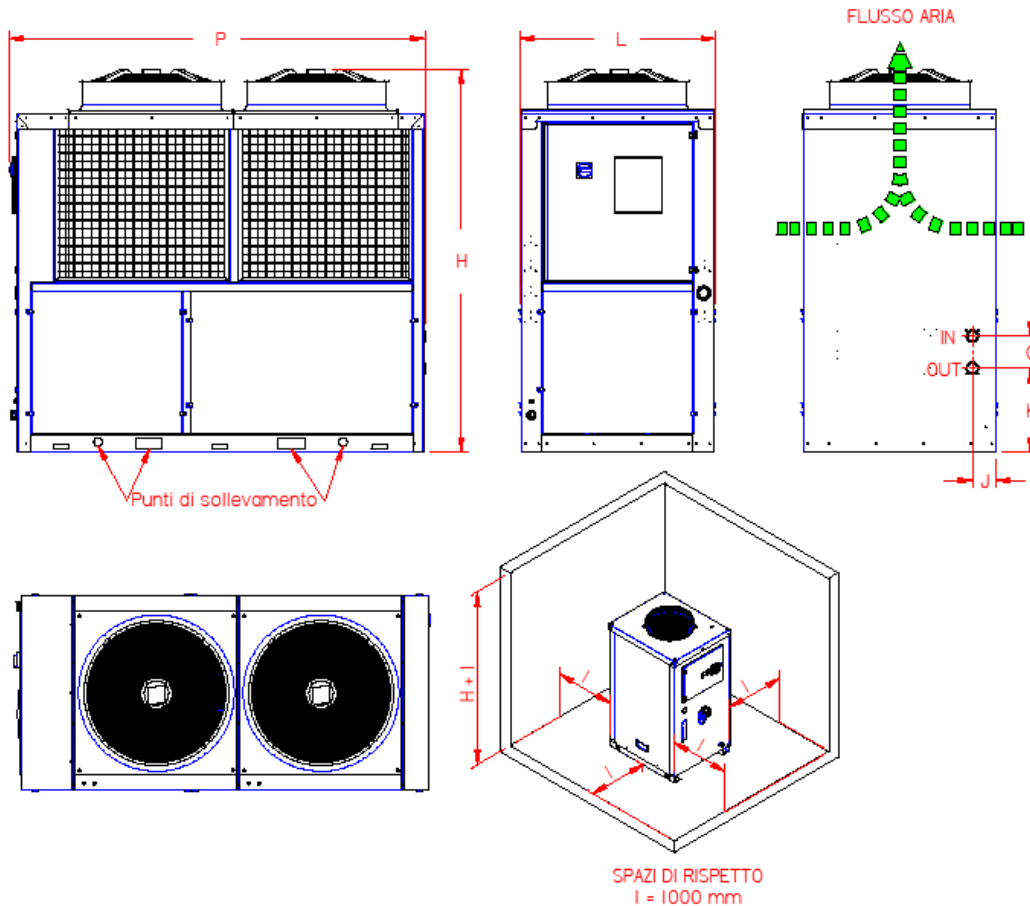

MOD.	(mm)						
	L	P	H	K	J	O	IN/OUT UNI ISO228
WLA J0-L0-M7	1140	2400	2200	500	140	190	2" G

TECHNICAL DATA

WLA COMPACT

Technical Data		WLA14	WLA20	WLA28	WLA41	WLA45
Capacità di raffreddamento W15L32 - Cooling capacity W15L32 - Kühlleistung W15L32 - Capacité refroidissement W15L32	Kw	1,1	1,9	2,5	3,5	4,2
Gas Refrigerante -Refrigerant gas - Kühlmittel - Gaz Réfrigérant		R134a	R134a	R134a	R134a	R134a
Alimentazione secondari - Secondaries feed - Betriebsspannung der Hilfsschaltkreise - Tension des circuits auxiliaires	Vac	230	230	230	230	230
Tensione/Fase/Frequenza - Voltage /Phase/Frequency Zulässige Variation Spannung/Frequenz - Volts/phase/fréquence	V/ph/Hz	230/1/50-60	230/1/50-60	230/1/50-60	230/1/50-60	230/1/50-60
Potenza elettrica assorbita max - Absorbed Electrical power max - Leistungsaufnahme max - Puissance absorbé max	kW	1,37	1,59	1,98	3,1	3,94
Corrente assorbita max -Current absorbed max - Nennstrom max -Courant absorbé max	A	7,1	7,7	10,7	14,3	15,5
Corrente di spunto - Locked rotor current - Blockierter rotorstrom - Courant rotor bloqué	A	18	20	38	44	47

Tipo di compressore – Compressor type - Verdichter - Compresseur		Alternative	Alternative	Alternative	Alternative	Alternative
Ventilatore - Fan - Lüfter - Ventilateur		Axial nr.1 x Ø 300	Axial nr.1 x Ø 300	Axial nr.1 x Ø 300	Axial nr.1 x Ø 300	Axial nr.1 x Ø 300
Portata aria a bocca libera - Condenser fan air flow (free) Luftdurchsatz Kondensatorenlüfter freie Öffnung - Débit d'air ventilateur condenseur bouche libre	m ³ /h	800	800	2100	2100	2100
Capacità della vasca – Tank capacity – Tankinhalt - capacité de bac	Lt.	18	18	18	18	18
Portata acqua - Water flow - Durchfluss – Portee d'Eau	l/1'	3,1	5,7	7,1	10	13
Prevalenza disponibile - Available head - Erhältliche Förderhöhe – Hauteur d'elevation disponible	bar	3,7	3,5	3,5	3,3	3
Prevalenza max – Pressure max – Druck max – Pression max	bar	5	5	5	5	5
Peso a vuoto - Weight empty - Leergewicht – Poid à vide	Kg	70	70	80	80	85
Attacchi idraulici - Hydraulic connections - Hydraulische Anschlüsse - Raccords hydrauliques		UNI ISO228 2 x 1/2"gas	UNI ISO228 2 x 1/2"gas	UNI ISO228 2 x 1/2"gas	UNI ISO228 2 x 1/2"gas	UNI ISO228 2 x 1/2"gas
Rumorosità max - Noise level max– Geräuschpegel max - Bruit max (*)	dB (A)	44	45	45	47	47

WRA VERTICAL

Technical Data		WRA13	WRA20
Capacità di raffreddamento W15L32 - Cooling capacity W15L32 - Kühlleistung W15L32 - Capacité refroidissement W15L32	kW	1,1	1,9
Gas Refrigerante –Refrigerant gas - Kühlmittel – Gaz Réfrigérant		R134a	
Alimentazione secondari - Secondaries feed - Betriebsspannung der Hilfsschaltkreise – Tension des circuits auxiliaires	Vac	230	
Tensione/Fase/Frequenza - Voltage /Phase/Frequency - Zulässige Variation Spannung/Frequenz - Volts/phase/fréquence	V/ph/Hz	230/1/50-60	
Potenza elettrica assorbita max - Absorbed Electrical power max - Leistungsaufnahme max - Puissance absorbé max	kW	1,2	1,6
Corrente assorbita max –Current absorbed max – Nennstrom max –Courant absorbé max	A	7	7,7
Corrente di spunto – Locked rotor current - Blockierter rotorstrom – Courant rotor bloqué	A	20	25
Tipo di compressore – Compressor type - Verdichter - Compresseur		Alternative	
Ventilatore - Fan - Lüfter - Ventilateur		Axial nr.1 x Ø300	
Portata aria a bocca libera - Condenser fan air flow (free) Luftdurchsatz Kondensatorenlüfter freie Öffnung - Débit d'air ventilateur condenseur bouche libre	m ³ /h	800	
Capacità della vasca – Tank capacity – Tankinhalt - capacité de bac	Lt.	18	
Portata acqua - Water flow - Durchfluss – Portee d'Eau	l/1'	3	5
Prevalenza disponibile - Available head - Erhältliche Förderhöhe – Hauteur d'elevation disponible	bar	3,7	3,5
Prevalenza max – Pressure max – Druck max – Pression max	bar	5	5
Peso a vuoto - Weight empty - Leergewicht – Poid à vide	Kg	75	
Attacchi idraulici - Hydraulic connections - Hydraulische Anschlüsse - Raccords hydrauliques		UNI ISO228 2 x 1/2"gas	
Rumorosità max - Noise level max– Geräuschpegel max - Bruit max (*)	dB (A)	44	45

WRA VERTICAL

Technical Data		WRA35	WRA45	WRA58	WRA70	WRA85
Capacità di raffreddamento W15L32 - Cooling capacity W15L32 - Kühlleistung W15L32 - Capacité refroidissement W15L32	kW	3,6	4,7	5,6	7,4	9
Gas Refrigerante –Refrigerant gas - Kühlmittel – Gaz Réfrigérant		R134a	R134a	R407C	R407C	R407C
Alimentazione secondari - Secondaries feed - Betriebsspannung der Hilfsschaltkreise – Tension des circuits auxiliaires	Vac	230	230	24	24	24
Tensione/Fase/Frequenza - Voltage /Phase/Frequency - Zulässige Variation Spannung/Frequenz - Volts/phase/fréquence	V/ph/Hz	230/1/50-60	230/1/50-60	400/3/50 460/3/60	400/3/50 460/3/60	400/3/50 460/3/60
Potenza elettrica assorbita max - Absorbed Electrical power max - Leistungsaufnahme max - Puissance absorbé max	kW	2,54	2,4	2,73	3,4	4,2
Corrente assorbita max –Current absorbed max – Nennstrom max –Courant absorbé max	A	8,3	12	5,5	6,5	8,23
Corrente di spunto – Locked rotor current - Blockierter rotorstrom – Courrant rotor bloqué	A	44	47	24	24	40
Tipo di compressore – Compressor type - Verdichter - Compresseur		Alternative	Alternative	Scroll	Scroll	Scroll
Ventilatore - Fan - Lüfter - Ventilateur		Axial nr.1 x Ø300	Axial nr.1 x Ø300	Axial nr.1 x Ø350	Axial nr.1 x Ø350	Axial nr.1x Ø400
Portata aria a bocca libera - Condenser fan air flow (free) - Luftdurchsatz Kondensatorenlüfter freie Öffnung - Débit d'air ventilateur condenseur bouche libre	m ³ /h	1885	1885	3110	3110	4200
Capacità della vasca – Tank capacity – Tankinhalt - capacité de bac	Lt.	40	40	40	40	40
Portata acqua - Water flow - Durchfluss – Portee d'Eau	l/1'	10	14	16	21	26
Prevalenza disponibile - Available head - Erhältliche Förderhöhe – Hauteur d'elevation disponible	bar	3,3	2,9	2,8	2,3	3,1
Prevalenza max – Pressure max – Druck max – Pression max	bar	10	10	10	10	10
Peso a vuoto - Weight empty - Leergewicht – Poid à vide	Kg	90	105	115	140	150
Attacchi idraulici - Hydraulic connections - Hydraulische Anschlüsse - Raccords hydrauliques		UNI ISO228 2 x 3/4"gas	UNI ISO228 2 x 3/4"gas	UNI ISO228 2 x 3/4"gas	UNI ISO228 2 x 3/4"gas	UNI ISO228 2 x 3/4"gas
Rumorosità max - Noise level max– Geräuschpegel max - Bruit max (*)	dB (A)	45	45	48	52	56

WRA VERTICAL

Technical Data		WRA95	WRAA3	WRAA6
Capacità di raffreddamento W15L32 - Cooling capacity W15L32 - Kühlleistung W15L32 - Capacité refroidissement W15L32	kW	10,3	12,9	16
Gas Refrigerante –Refrigerant gas - Kühlmittel – Gaz Réfrigérant		R407C	R407C	R407C
Alimentazione secondari - Secondaries feed - Betriebsspannung der Hilfsschaltkreise – Tension des circuits auxiliaires	Vac	24	24	24
Tensione/Fase/Frequenza - Voltage /Phase/Frequency - Zulässige Variation Spannung/Frequenz - Volts/phase/fréquence	V/ph/Hz	400/3/50 460/3/60	400/3/50 460/3/60	400/3/50 460/3/60
Potenza elettrica assorbita max - Absorbed Electrical power max - Leistungsaufnahme max - Puissance absorbé max	kW	5,57	6,32	7,5
Corrente assorbita max –Current absorbed max – Nennstrom max –Courant absorbé max	A	10,2	11,6	12,4
Corrente di spunto – Locked rotor current - Blockierter rotorstrom – Courrant rotor bloqué	A	46	50	65
Tipo di compressore – Compressor type - Verdichter - Compresseur		Scroll	Scroll	Scroll

Ventilatore - Fan - Lüfter - Ventilateur		Axial nr.1 x Ø500	Axial nr.1 x Ø500	Axial nr.1 x Ø500
Portata aria a bocca libera - Condenser fan air flow (free) - Luftdurchsatz Kondensatorlüfter freie Öffnung - Débit d'air ventilateur condenseur bouche libre	m ³ /h	9700	9700	9700
Capacità della vasca - Tank capacity - Tankinhalt - capacité de bac	Lt.	100	100	100
Portata acqua - Water flow - Durchfluss - Portee d'Eau	l/1'	30	37	45
Prevalenza disponibile - Available head - Erhältliche Förderhöhe - Hauteur d'elevation disponible	bar	2,8	2,7	2,6
Prevalenza max - Pressure max - Druck max - Pression max	bar	10	10	10
Peso a vuoto - Weight empty - Leergewicht - Poids à vide	Kg	190	230	250
Attacchi idraulici - Hydraulic connections - Hydraulische Anschlüsse - Raccords hydrauliques		UNI ISO228 2 x 1"gas	UNI ISO228 2 x 1"gas	UNI ISO228 2 x 1"gas
Rumorosità max - Noise level max- Geräuschpegel max - Bruit max (*)	dB (A)	58	58	62

WRA VERTICAL

Technical Data		WRAA8	WRAB4	WRAB8	WRAC2
Capacità di raffreddamento W15L32 - Cooling capacity W15L32 - Kühlleistung W15L32 - Capacité refroidissement W15L32	kW	18,9	24,1	29,3	33
Gas Refrigerante -Refrigerant gas - Kühlmittel - Gaz Réfrigérant		R407C	R407C	R407C	R407C
Alimentazione secondari - Secondaries feed - Betriebsspannung der Hilfsschaltkreise - Tension des circuits auxiliaires	Vac	24	24	24	24
Tensione/Fase/Frequenza - Voltage /Phase/Frequency - Zulässige Variation Spannung/Frequenz - Volts/phase/fréquence	V/ph/Hz	400/3/50 460/3/60	400/3/50 460/3/60	400/3/50 460/3/60	400/3/50 460/3/60
Potenza elettrica assorbita max - Absorbed Electrical power max Leistungsaufnahme max - Puissance absorbé max	kW	8,4	12,1	13,25	15,1
Corrente assorbita max -Current absorbed max - Nennstrom max -Courant absorbé max	A	15	20	22,3	27
Corrente di spunto - Locked rotor current - Blockierter rotorstrom - Courant rotor bloqué	A	74	99	123	127
Tipo di compressore - Compressor type - Verdichter - Compresseur		Scroll	Scroll	Scroll	Scroll
Ventilatore - Fan - Lüfter - Ventilateur		Axial nr.1 x Ø630	Axial nr.1 x Ø630	Axial nr.1 x Ø630	Axial nr.1 x Ø630
Portata aria a bocca libera - Condenser fan air flow (free) Luftdurchsatz Kondensatorlüfter freie Öffnung - Débit d'air ventilateur condenseur bouche libre	m ³ /h	11000	11000	11000	20000
Capacità della vasca - Tank capacity - Tankinhalt - capacité de bac	Lt.	180	180	180	180
Portata acqua - Water flow - Durchfluss - Portee d'Eau	l/1'	54	70	84	92
Prevalenza disponibile - Available head - Erhältliche Förderhöhe - Hauteur d'elevation disponible	bar	2,5	2,6	2,4	2,3
Prevalenza max - Pressure max - Druck max - Pression max	bar	10	10	10	10
Peso a vuoto - Weight empty - Leergewicht - Poids à vide	Kg	320	360	390	390
Attacchi idraulici - Hydraulic connections - Hydraulische Anschlüsse - Raccords hydrauliques		UNI ISO228 2 x 1 1/4"gas	UNI ISO228 2 x 1 1/4"gas	UNI ISO228 2 x 1 1/4"gas	UNI ISO228 2 x 1 1/4"gas
Rumorosità max - Noise level max- Geräuschpegel max - Bruit max (*)	dB (A)	60	60	61	69

WRA VERTICAL

Technical Data		WRAC8	WRAD8
Capacità di raffreddamento W15L32 - Cooling capacity W15L32 - Kühlleistung W15L32 - Capacité refroidissement W15L32	kW	41,2	51
Gas Refrigerante –Refrigerant gas - Kühlmittel – Gaz Réfrigérant		R407C	R407C
Alimentazione secondari - Secondaries feed - Betriebsspannung der Hilfsschaltkreise – Tension des circuits auxiliaires	Vac	24	24
Tensione/Fase/Frequenza - Voltage /Phase/Frequency - Zulässige Variation Spannung/Frequenz - Volts/phase/fréquence	V/ph/Hz	400/3/50 460/3/60	400/3/50 460/3/60
Potenza elettrica assorbita max - Absorbed Electrical power max Leistungsaufnahme max - Puissance absorbé max	kW	19,7	21
Corrente assorbita max –Current absorbed max – Nennstrom max –Courant absorbé max	A	33,4	35
Corrente di spunto – Locked rotor current - Blockierter rotorstrom – Courrant rotor bloqué	A	167	198
Tipo di compressore – Compressor type - Verdichter - Compresseur		Scroll	Scroll
Ventilatore - Fan - Lüfter - Ventilateur		Axial nr.1 x Ø800	Axial nr.1 x Ø800
Portata aria a bocca libera - Condenser fan air flow (free)Luftdurchsatz Kondensatorenlüfter freie Öffnung - Débit d'air ventilateur condenseur bouche libre	m ³ /h	26000	25000
Capacità della vasca – Tank capacity – Tankinhalt - capacité de bac	Lt.	180	180
Portata acqua - Water flow - Durchfluss – Portee d'Eau	l/1'	120	147
Prevalenza disponibile - Available head - Erhältliche Förderhöhe – Hauteur d'elevation disponible	bar	3,5	3,3
Prevalenza max – Pressure max – Druck max – Pression max	bar	10	10
Peso a vuoto - Weight empty - Leergewicht – Poid à vide	Kg	450	470
Attacchi idraulici - Hydraulic connections - Hydraulische Anschlüsse - Raccords hydrauliques		UNI ISO228 2 x 1 1/2"gas	UNI ISO228 2 x 1 1/2"gas
Rumorosità max - Noise level max– Geräuschpegel max - Bruit max (*)	dB (A)	67	67

WLA PRECISION

Technical Data		WLAB8	WLAC2	WLAC8	WLAD8	WLAG2	WLAH8
Capacità di raffreddamento W15L32 - Cooling capacity W15L32 - Kühlleistung W15L32 - Capacité refroidissement W15L32	kW	29	32	41	51	72	90,5
Gas Refrigerante –Refrigerant gas - Kühlmittel – Gaz Réfrigérant		R407C	R407C	R407C	R407C	R407C	R407C
Alimentazione secondari - Secondaries feed - Betriebsspannung der Hilfsschaltkreise – Tension des circuits auxiliaires	Vac	24	24	24	24	24	24
Tensione/Fase/Frequenza - Voltage /Phase/Frequency - Zulässige Variation Spannung/Frequenz - Volts/phase/fréquence	V/ph/Hz	400/3/50 460/3/60	400/3/50 460/3/60	400/3/50 460/3/60	400/3/50 460/3/60	400/3/50 460/3/60	400/3/50 460/3/60
Potenza elettrica assorbita max - Absorbed Electrical power max Leistungsaufnahme max - Puissance absorbé max	kW	13,25	15,1	19,5	25,2	31	36
Corrente assorbita max –Current absorbed max – Nennstrom max –Courant absorbé max	A	22,3	27	33	42,8	51	60,1

Corrente di spunto – Locked rotor current - Blockierter rotorstrom – Courrant rotor bloqué	A	123	127	167	198	225	272
Tipo di compressore – Compressor type - Verdichter - Compresseur		Scroll	Scroll	Scroll	Scroll	Scroll	Scroll
Ventilatore - Fan - Lüfter - Ventilateur		Axial nr.2 x Ø500	Axial nr.2 x Ø500	Axial nr.2 x Ø630	Axial nr.2 x Ø630	Axial nr.2 x Ø630	Axial nr.2 x Ø630
Portata aria a bocca libera - Condenser fan air flow (free)Luftdurchsatz Kondensatorenlüfter freie Öffnung - Débit d'air ventilateur condenseur bouche libre	m ³ /h	19000	19000	30000	30000	36000	36000
Capacità della vasca – Tank capacity – Tankinhalt - capacité de bac	Lt.	100	100	300	300	300	300
Portata acqua - Water flow - Durchfluss – Portee d'Eau	l/1'	84	92	120	147	200	260
Prevalenza disponibile - Available head - Erhältliche Förderhöhe – Hauteur d'elevation disponible	bar	2,9	3,1	3,5	3,3	2,6	2,4
Prevalenza max – Pressure max – Druck max – Pression max	bar	10	10	10	10	10	10
Peso a vuoto - Weight empty - Leergewicht – Poid à vide	Kg	400	450	650	750	850	950
Attacchi idraulici - Hydraulic connections - Hydraulische Anschlüsse - Raccords hydrauliques		UNI ISO228 2 x 1 1/4"gas	UNI ISO228 2 x 1 1/4"gas	UNI ISO228 2 x 1 1/2"gas	UNI ISO228 2 x 1 1/2"gas	UNI ISO228 2 x 1 1/2"gas	UNI ISO228 2 x 1 1/2"gas
Rumorosità max - Noise level max– Geräuschpegel max - Bruit max (*)	dB (A)	67	67	70	70	72	74

WLA PRECISION R410A

Technical Data		WLAJ0	WLAL0	WLAM7
Capacità di raffreddamento W15L32 - Cooling capacity W15L32 - Kühlleistung W15L32 - Capacité refroidissement W15L32	kW	96	112	130
Gas Refrigerante –Refrigerant gas - Kühlmittel – Gaz Réfrigérant		R410A	R410A	R410A
Alimentazione secondari - Secondaries feed - Betriebsspannung der Hilfsschaltkreise – Tension des circuits auxiliaires	Vac	24	24	24
Tensione/Fase/Frequenza - Voltage /Phase/Frequency - Zulässige Variation Spannung/Frequenz - Volts/phase/fréquence	V/ph/Hz	400/3/50	400/3/50	400/3/50
Potenza elettrica assorbita max - Absorbed Electrical power max - Leistungsaufnahme max - Puissance absorbé max	kW	41,5	48,6	51,4
Corrente assorbita max –Current absorbed max –Nennstrom max –Courant absorbé max	A	72	77,6	92,1
Corrente di spunto – Locked rotor current - Blockierter rotorstrom – Courrant rotor bloqué	A	141	160	191
Tipo di compressore – Compressor type - Verdichter - Compresseur		Scroll	Scroll	Scroll
Ventilatore - Fan - Lüfter - Ventilateur		Axial nr.2 x Ø800	Axial nr.2 x Ø800	Axial nr.2 x Ø800
Portata aria a bocca libera - Condenser fan air flow (free)Luftdurchsatz Kondensatorenlüfter freie Öffnung - Débit d'air ventilateur condenseur bouche libre	m ³ /h	48000	48000	48000
Capacità della vasca – Tank capacity – Tankinhalt - capacité de bac	Lt.	300	300	300
Portata acqua - Water flow - Durchfluss – Portee d'Eau	l/1'	270	320	370
Prevalenza disponibile - Available head - Erhältliche Förderhöhe – Hauteur d'elevation disponible	bar	2,2	2	1,8
Prevalenza max – Pressure max – Druck max – Pression max	bar	10	10	10
Peso a vuoto - Weight empty - Leergewicht – Poid à vide	Kg	950	1100	1200

Attacchi idraulici - Hydraulic connections - Hydraulische Anschlüsse - Raccords hydrauliques		UNI ISO228 2 x 2"gas	UNI ISO228 2 x 2"gas	UNI ISO228 2 x 2"gas
Rumorosità max - Noise level max- Geräuschpegel max - Bruit max (*)	dB (A)	74	74	74

ORA O-FLOW

Technical Data		ORA20	ORA34	ORA43	ORA58	ORA70
Capacità di raffreddamento O30L32 - Cooling capacity O30L32 - Kühlleistung O30L32 - Capacité refroidissement O30L32	kW	2,1	3,4	4,3	5,8	7
Gas Refrigerante -Refrigerant gas - Kühlmittel - Gaz Réfrigérant		R134a	R134a	R134a	R407C	R407C
Alimentazione secondari - Secondaries feed - Betriebsspannung der Hilfsschaltkreise - Tension des circuits auxiliaires	Vac	230 (24)	24	24	24	24
Tensione/Fase/Frequenza - Voltage /Phase/Frequency - Zulässige Variation Spannung/Frequenz - Volts/phase/fréquence	V/ph/Hz	230/1/50 (400/3/50)	400/3/50 460/3/60	400/3/50 460/3/60	400/3/50 460/3/60	400/3/50 460/3/60
Potenza elettrica assorbita max - Absorbed Electrical power max Leistungsaufnahme max - Puissance absorbé max	kW	1,2	2,6	3,2	3,3	3,8
Corrente assorbita max -Current absorbed max - Nennstrom max -Courant absorbé max	A	7	7,1	7,4	5,7	7,3
Corrente di spunto - Locked rotor current - Blockierter rotorstrom - Courant rotor bloqué	A	32	25	25	24	40
Tipo di compressore - Compressor type - Verdichter - Compresseur		Alternative	Alternative	Alternative	Scroll	Scroll
Ventilatore - Fan - Lüfter - Ventilateur		Axial nr.1 x Ø250	Axial nr.1 x Ø300	Axial nr.1 x Ø300	Axial nr.1 x Ø300	Axial nr.1 x Ø350
Portata aria a bocca libera - Condenser fan air flow (free)Luftdurchsatz Kondensatorenlüfter freie Öffnung - Débit d'air ventilateur condenseur bouche libre	m ³ /h	1200	1800	1800	4100	4100
Capacità della vasca - Tank capacity - Tankinhalt - capacité de bac	Lt.		20	40	40	40
Portata olio - Oil flow - Durchfluss - Débit de l'huile	l/1'	8,5	16	16	25	25
Prevalenza disponibile - Available head - Erhältliche Förderhöhe - Hauteur d'elevation disponible	bar	10	10	10	10	10
Prevalenza max - Pressure max - Druck max - Pression max	bar	10	10	10	10	10
Peso a vuoto - Weight empty - Leergewicht - Poids à vide	Kg	80	100	115	115	150
Attacchi idraulici - Hydraulic connections - Hydraulische Anschlüsse - Raccords hydrauliques		UNI ISO228 2 x 1/2"gas	UNI ISO228 2 x 3/4"gas	UNI ISO228 2 x 3/4"gas	UNI ISO228 2 x 3/4"gas	UNI ISO228 2 x 3/4"gas
Rumorosità max - Noise level max- Geräuschpegel max - Bruit max (*)	dB (A)	44	45	45	48	52

ORA O-FLOW

Technical Data		ORA95	ORAA3	ORAA6
Capacità di raffreddamento O30L32 - Cooling capacity O30L32 Kühlleistung O30L32 - Capacité refroidissement O30L32	kW	10	13	16
Gas Refrigerante -Refrigerant gas - Kühlmittel - Gaz Réfrigérant		R407C	R407C	R407C
Alimentazione secondari - Secondaries feed - Betriebsspannung der Hilfsschaltkreise - Tension des circuits auxiliaires	Vac	24	24	24
Tensione/Fase/Frequenza - Voltage /Phase/Frequency Zulässige Variation Spannung/Frequenz - Volts/phase/fréquence	V/ph/Hz	400/3/50 460/3/60	400/3/50 460/3/60	400/3/50 460/3/60
Potenza elettrica assorbita max - Absorbed Electrical power max Leistungsaufnahme max - Puissance absorbé max	kW	7,41	9,31	10,95
Corrente assorbita max -Current absorbed max -Nennstrom max -Courant absorbé max	A	13,25	16	16,9

Corrente di spunto – Locked rotor current - Blockierter rotorstrom – Courrant rotor bloqué	A	46	50	63
Tipo di compressore – Compressor type - Verdichter - Compresseur		Scroll	Scroll	Scroll
Ventilatore - Fan - Lüfter - Ventilateur		Axial nr.1 x Ø500	Axial nr.1 x Ø500	Axial nr.1 x Ø500
Portata aria a bocca libera - Condenser fan air flow (free)Luftdurchsatz Kondensatorlüfter freie Öffnung - Débit d'air ventilateur condenseur bouche libre	m ³ /h	8000	8000	8000
Capacità della vasca – Tank capacity – Tankinhalt - capacité de bac	Lt.	100	100	100
Portata olio - Oil flow - Durchfluss – Débit de l'huile	l/1'	38	50	50
Prevalenza disponibile - Available head - Erhältliche Förderhöhe – Hauteur d'elevation disponible	bar	10	10	10
Prevalenza max – Pressure max – Druck max – Pression max	bar	10	10	10
Peso a vuoto - Weight empty - Leergewicht – Poid à vide	Kg	200	220	250
Attacchi idraulici - Hydraulic connections - Hydraulische Anschlüsse - Raccords hydrauliques		UNI ISO228 2 x 1"gas	UNI ISO228 2 x 1"gas	UNI ISO228 2 x 1"gas
Rumorosità max - Noise level max– Geräuschpegel max - Bruit max (*)	dB (A)	58	58	60

Correction Factors Table

CORRECTION FACTORS TO CALCULATE THE CHILLER COOLING CAPACITY								
Air Temp °C	15	20	25	27	30	32	35	40
Correction Factor F1	1,15	1,12	1,07	1,05	1,02	1	0,96	0,89
Outgoing Water Temp °C	5	10	15	20	25			
Correction Factor F2	0,84	0,93	1	1,05	1,15			
% Glycol	0	10	20	30	40	50		
Correction Factor F3	1	0,99	0,98	0,97	0,96	0,95		

To determine the chiller power under different cooling conditions, multiply the cooling capacity in the tables above by the three correction factors indicated in this table F1xF2xF3.

NOTE FOR WATER AND OIL CHILLERS:

Refer to the coolant liquid conditions/water temperature for the delivery and consumption conditions in the technical chart in the Manual, Part II.

Prevalence of the Standard Pumps



In dual frequency chillers (50-60Hz), the pump is optimised to work at 60Hz. Using them at 50Hz, the pressure drops about 20%. The prevalence is calculated using water without additives. If the water has additives, contact Aftersales.

WLA14-20-28-41-45 peripheral pump at 50-60Hz:

WRA13-20-35-45-58-70 peripheral pump at 50-60Hz:

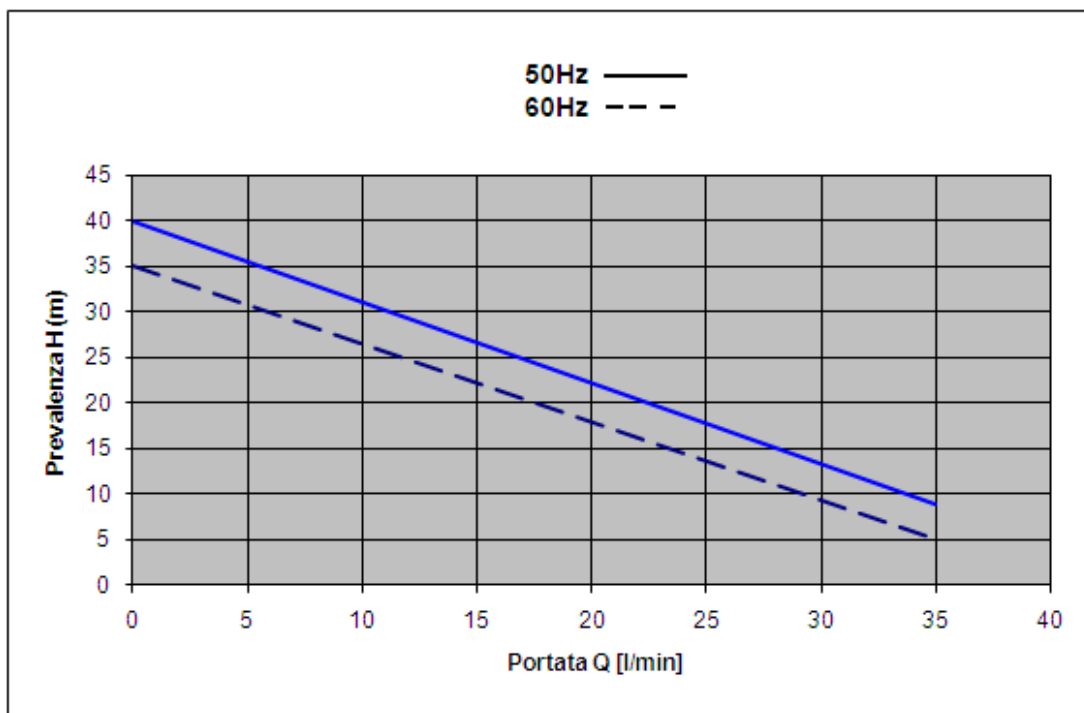

WRA85 peripheral pump at 50-60Hz:

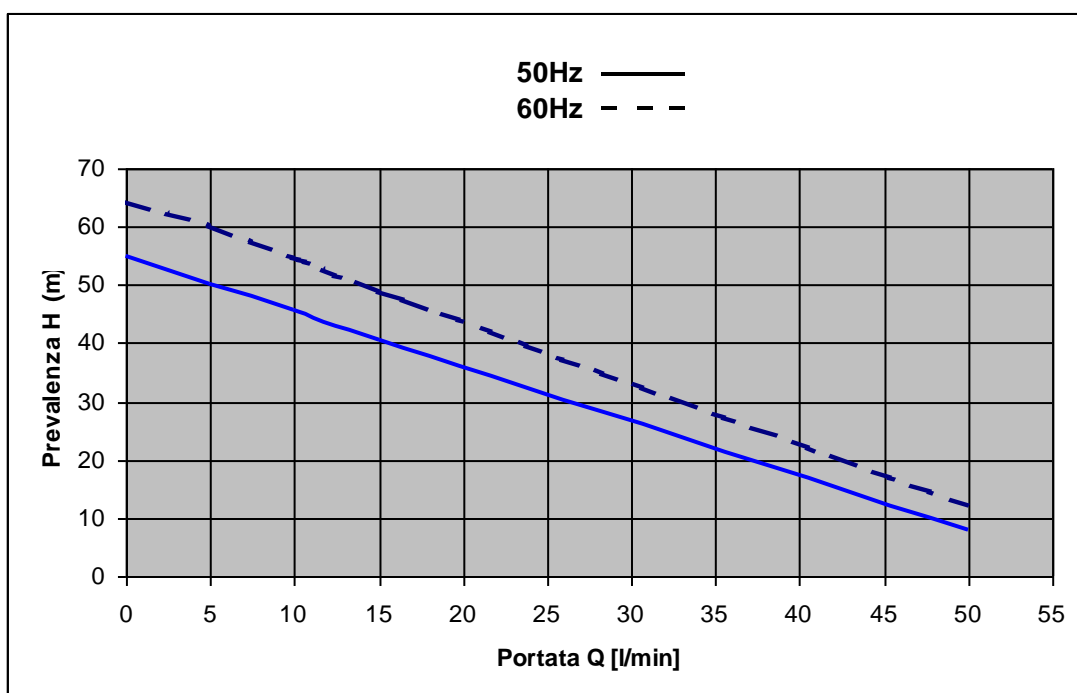

WRA95-A3-A6-A8 centrifuge pump at 50-60Hz:

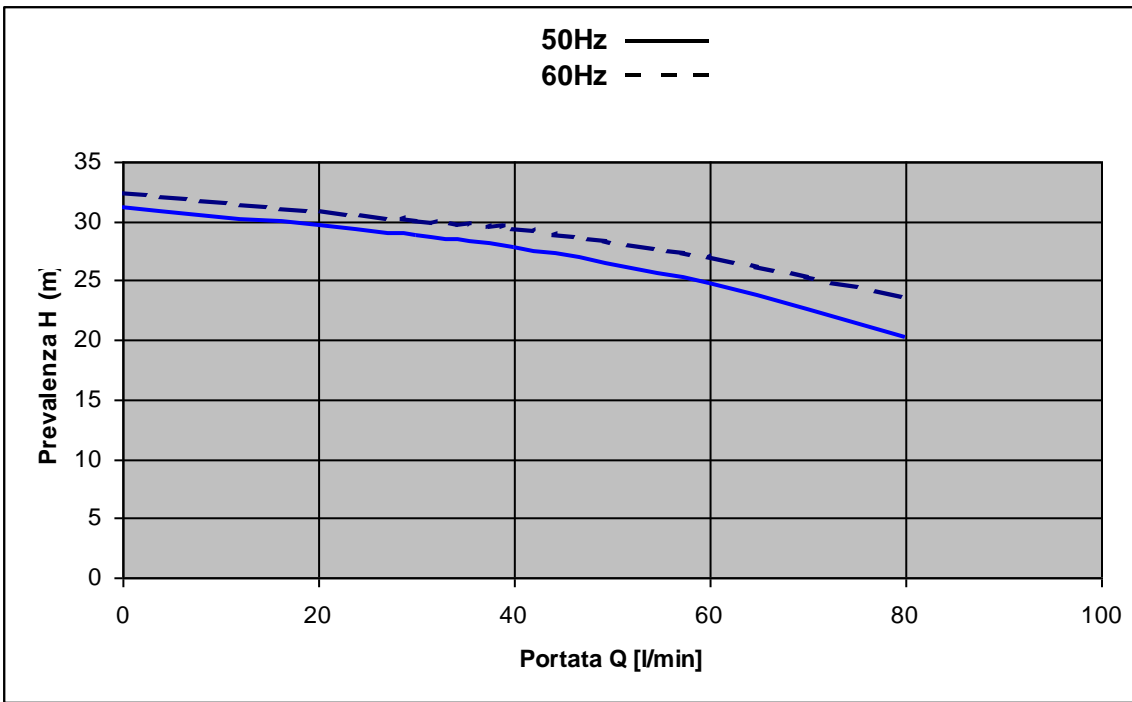

WRAB4-B8 centrifuge pump at 50-60Hz:

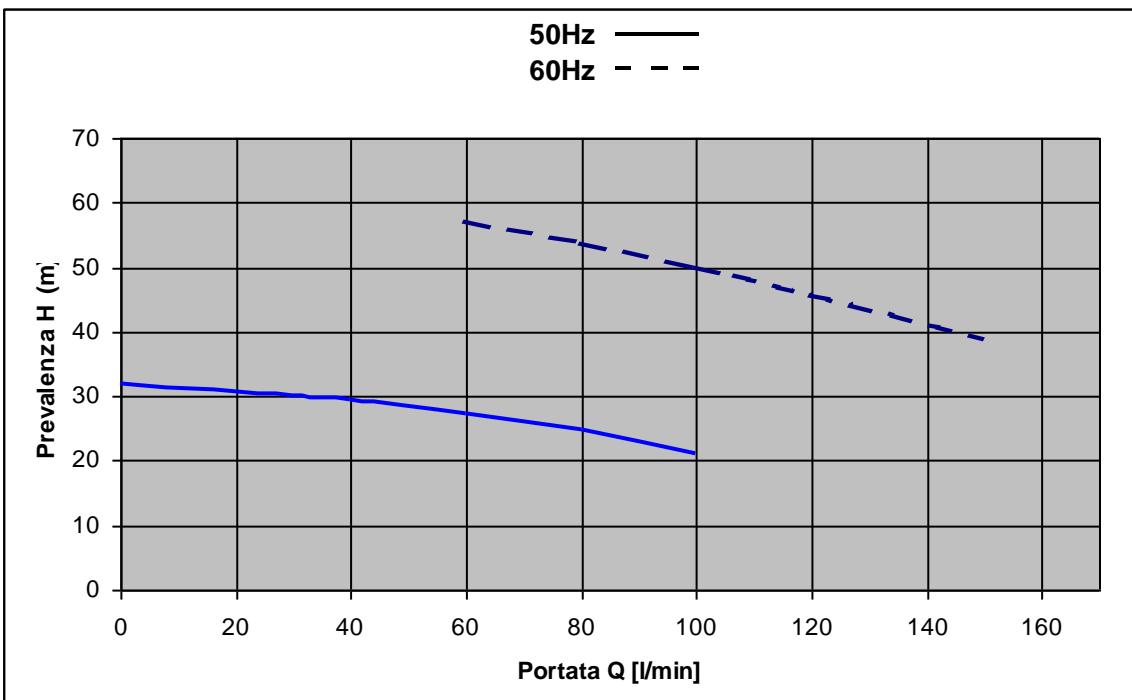

WRAC2 centrifuge pump at 50-60Hz:

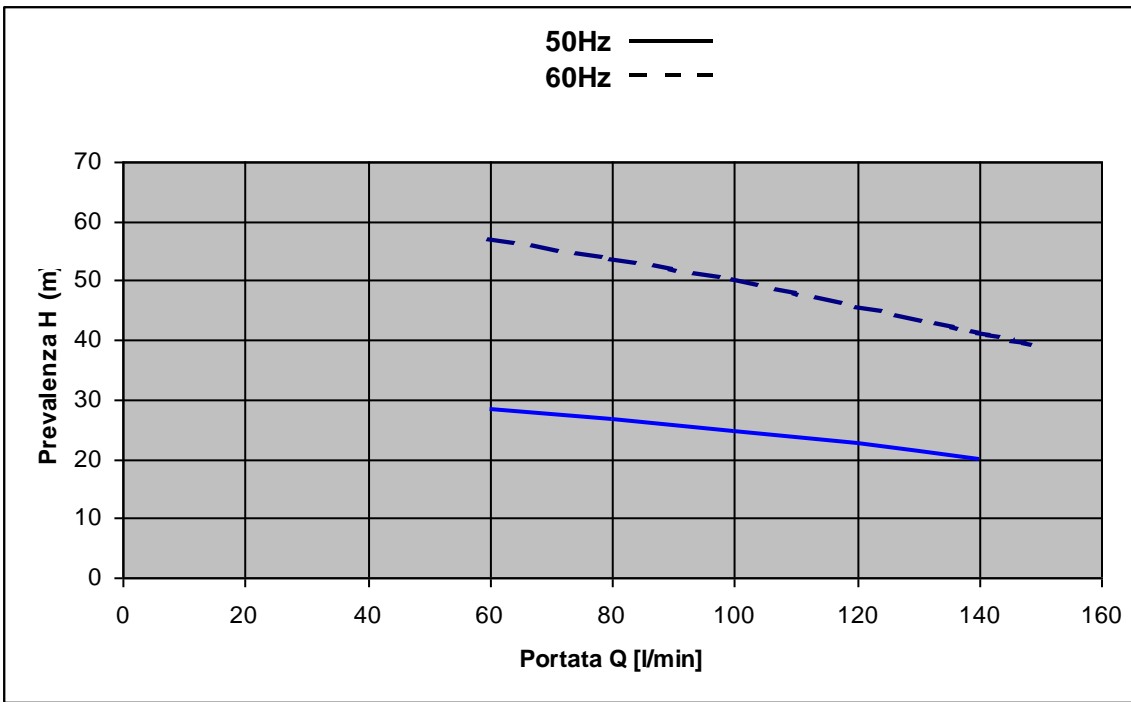

WRAC8-D8 centrifuge pump at 50-60Hz:
 WLAC8-D8 centrifuge pump at 50-60Hz:

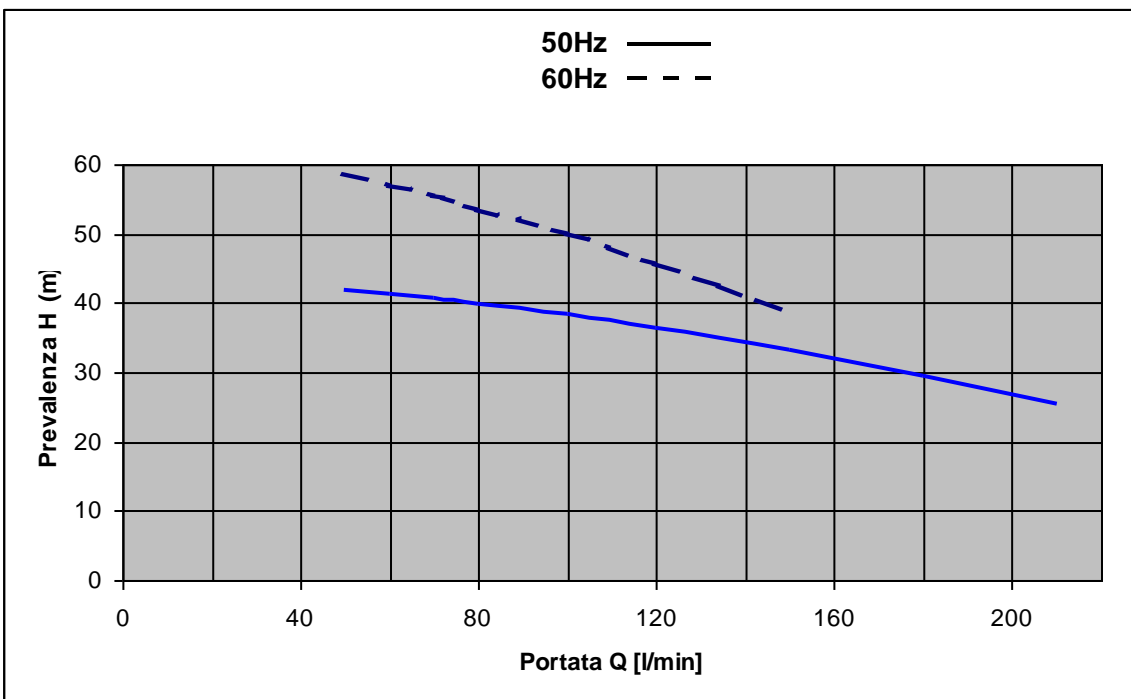

WLAG2-H8 centrifuge pump at 50-60Hz:

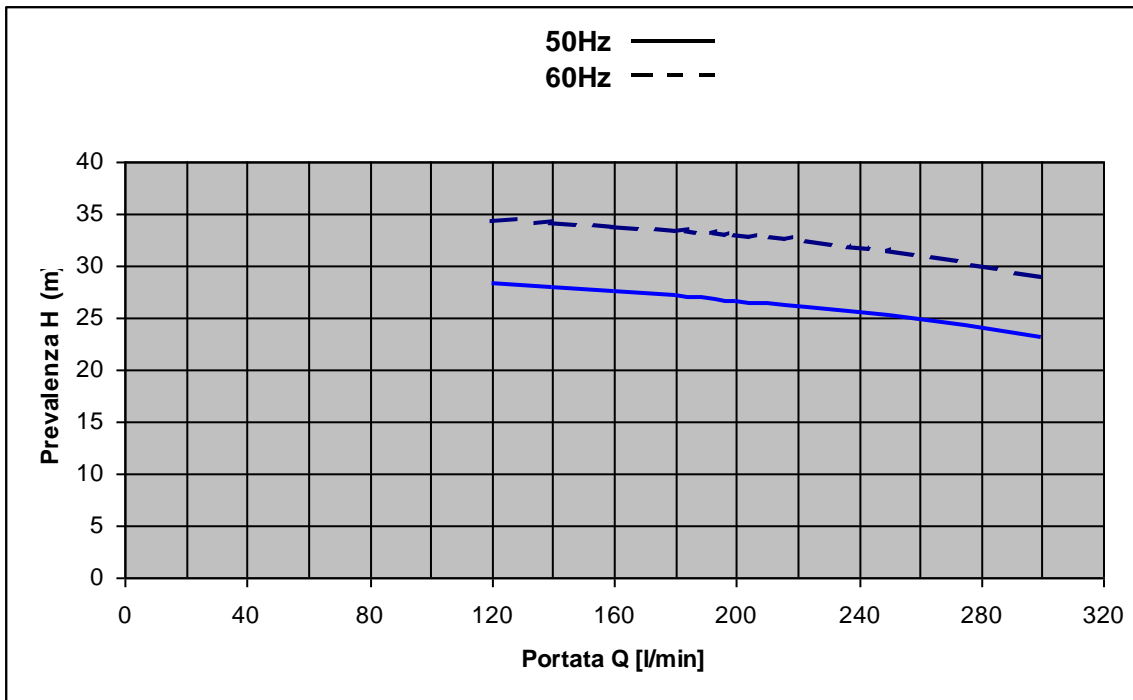

WLAJ0-L0-M7 centrifuge pump at 50-60Hz:

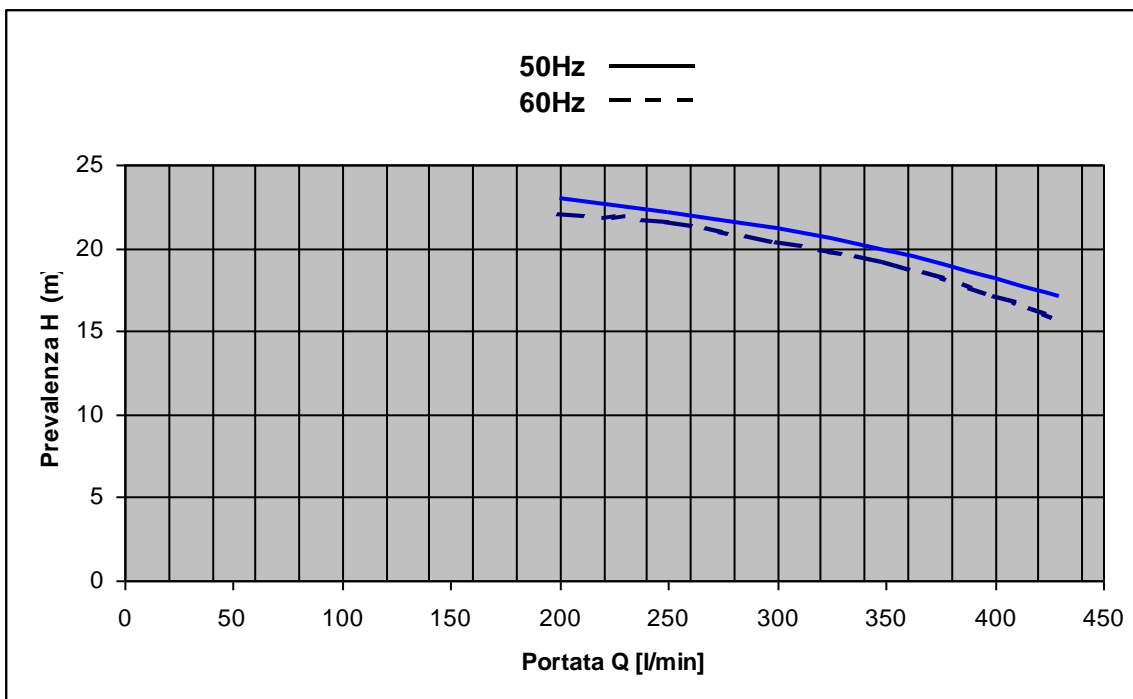

1.5 INTENDED AND UNINTENDED USE

INTENDED USE

Industrial cooling liquid is used in the chiller, far from heat sources, based on the instructions and limits indicated in the data label, excluding WLA PRECISION R410A.

INSTALLATION

- 1 - Position the unit in the place of use, carefully checking that the supporting surface, where it is leaning and to which it is secured, is levelled.
- 2 - The support area must be sufficient to bear the weight of the operating unit.
- 3 - The support plan must be adequately rigid so there is no shock or impact.

This device must be respected even if shock absorbers are installed.

UNINTENDED USE

The chiller must not be installed in moveable areas, on parts that transmit shocks, on oscillating parts and on (unleveled) inclined parts.

In general, the chiller must not be installed in the following situations:

- areas where there is excessive heat
- areas where there are strong magnetic fields
- areas where there are open flames
- areas where there is a risk of fire
- areas where there are inflammable products
- areas where there is the risk of explosion
- areas where there is a saline atmosphere
- areas where there is an aggressive environment
- areas where there is dust (no air filter)
- areas where there are oily clouds (no air filter)

If you have any questions, consult the manufacturer.

1.6 SAFETY

Definitions:

-dangerous area: any area inside and/or near the chiller where the presence of an exposed person constitutes a risk for health and safety.

-exposed person: any person who is in a dangerous area.

-operator/ maintenance person: staff qualified to take care of handling, installation, running and maintaining the chiller.

General Rules

-Unauthorized staff is prohibited from going near the chiller.

-Before each maintenance intervention, read and perform the operations described in chap. 3.

-It is prohibited to enter the chiller.

-It is prohibited to remove the protection panels, excluding safety and emergency devices.

-It is prohibited to climb on the chiller.



The manufacturer is not liable for damages deriving from the unintended use of the chiller or deriving from the changes and/or tampering with the chiller.

For handling, installation, ordinary and special maintenance, the operators and maintenance people must use the DPI in accordance with the safety manager and prevailing legislation.

DPI=individual protection devices: gloves, helmet, goggles, accident prevention shoes, etc.

Work on the electrical equipment must be done by a qualified electrician only.

Work on the hydraulic equipment must be done by a qualified plumber only.

Work on the chiller equipment must be done by a qualified chiller repair person only.

CLIENT PROTECTION DEVICES



The client must install a protection device mounted on the chiller's electrical line

NB typically there is a differential 0.3A switch, sized based on the max absorption (see data label).

1.7 RESIDUAL RISK

The description of the residual risk exams the following elements:

- type of risks for operators/maintenance people
- description of the risk
- safety measures adopted to residue the risk of accidents

RESIDUAL RISK NEAR THE CHILLER

- electrocution if the electrical hook-up is not up to standard or if it is not grounded.
- electrocution if the general switch is off because the power line is under tension
- cuts or burns in the presence of sharp objects
- Burns due to contact with high temperature surfaces

- aspiration and subsequent expulsion from fans of objects, dust and substances in the installation area.
- protection (launch) of tools and various nuts and bolts (screws, washers, etc) that could accidentally fall from the fan blades.
- forming condensation in the presence of dew with dripping in non-insulated tubing.
- altering the micro-climate during normal operations.
- creating noise during operations.
- water and additive leaks if there are issues
- oil leaks if there are issues
- fire of the assembly with lack of voltage (OFF machine status)
- ambient temperature increase (OFF machine status)
- condenser fan failure (ON machine status)
- condensing coil clogging on the cooling system (ON machine status)
- accidental closing of a shutoff valve during maintenance (ON machine status)
- maintenance error (OFF machine status)
- chiller gas leaks if there are issues

The coolant is a greenhouse gas. It is a vapour that is heavier than air that can cause suffocation by reducing the amount of oxygen in an environment saturated with coolant.

A coolant leak causes freezing when it comes in contact with the skin.

 SAFETY MEASURES IF THERE IS A COOLANT LEAK	
On the data label, the type and amount of coolant is indicated.	
INHALATION	<ul style="list-style-type: none"> • bring the person who fainted to a place where there is fresh air or outside or give him/her oxygen • provide oxygen if necessary • do not give water or medicine (unless requested by a doctor) • inform a doctor and/or urgent care facility
CONTACT WITH THE EYES	<ul style="list-style-type: none"> • carefully wash your eyes and rinse with large amounts of water for at least 15 minutes • inform a doctor and/or urgent care facility
CONTACT WITH THE SKIN	<ul style="list-style-type: none"> • remove contaminated clothes and wash with large amounts of water • inform a doctor and/or urgent care facility
INDIVIDUAL PRECAUTIONS	<ul style="list-style-type: none"> • remove staff to a safe area • ventilate the environment
ENVIRONMENTAL PRECAUTIONS	<ul style="list-style-type: none"> • no gas evaporates
CLEANING METHODS	<ul style="list-style-type: none"> • no gas evaporates

2.0 INSTALLATION AND CONNECTIONS

 The installation must be done by a qualified installer.

2.1 GENERAL INFORMATION

- The chiller must be located near the catchments to be chilled.
- The support base must be positioned horizontally and support the weight of the chiller in use.
- The chiller must be attached to the support base with shock absorbers.
- Check that there are free areas for maintenance.
- Check that air can circulate, using the condenser, be aspirated and expelled (only for air condensation versions).

2.2 HYDRAULIC CONNECTIONS

- The hydraulic connection must be done by a qualified installer.
- Check that the "INLET" and "OUTLET" hydraulic connections are respected.
- For distances more than 5m and positive and negative gaps between the chiller and the catchments, consult our technical office.
- The tubing section must be at the minimum the same diameter as the chiller's hydraulic hook-ups.

- Connect the tubing to the chiller using joints or flexible tubes.
- Install to switch valves to isolate (section) the chiller from the catchments.
- Install a filter on the return tube from the chiller (80-100 microns, Dp 0.2 bar)
- Install a flow meter on the return tube (provided upon request).
- Install a hydraulic by-pass to adjust the flow pressure (provided upon request).
- If there are pressurised closed circuits, install a venting valve on the highest points of the plant.
- If there is an automatic water load, install a backflow between the chiller and the hydraulic network (provided upon request).
- Before connecting the chiller to the catchments, check that the tubes used are not dirty or have residual waste. If there are any doubts, wash them one or more times.

2.3 ELECTRICAL CONNECTIONS

- The electrical hook-ups must be done by a qualified electrician.
- Before working on the electrical parts, make sure they are not under tension.
- Check that the electrical hook-up corresponds to that indicated on the chiller data label (tension, phase number, frequency).
- Connect the right size power cable.
- Connect the ground cable with the PE clamp available in the chiller's control panel.
- Connect the alarm signals if available (see electrical chart).
- connect the external ON-OFF control if provided (see electrical chart).
- Check the correct phase sequence.
- To adjust the revolutions and aux circuit transformer, see the electrical chart. The correct direction of rotation is shown on the motors by an arrow. With regard to scroll/rotary compressors, if they are placed in a unit with control panel installed and with other motors (pumps/fans), it is sufficient that the latter respect the correct rotation direction and the compressor will do so accordingly. In case the compressor is installed in a system with no three-phase motors, with a remote control panel or separate power supplies (e.g. quick connectors that feed the single motor), proceed as follows:
 - SCROLL COMPRESSOR: The reverse rotation produces an operating noise exceeding the noise produced during the regular rotation, at the same time the current consumption is substantially reduced from the value shown in the wiring diagram and the cooling capacity is not fulfilled (Value close to 0 kW)
CAUTION: if connected incorrectly the thermal protector can operate to protect the compressor. If the connection is not properly restored, the compressor may be irretrievably damaged.
 - ROTARY COMPRESSOR: check that the cooling capacity is fulfilled, if this does not occur it means that gas does not circulate in the system resulting from the wrong rotation direction.

2.4 OPERATIONS

In this unit its possible to use tap water which respects the values reported in the table below. We recommend the use of premixed fluid COSMOTEC No frost N25 / N39 or COSMOTEC No frost L38. Alternatively its possible to use Clariant Antifrogen N or Clariant Antifrogen L, respecting the concentrations recommended in the data sheet of the product.



Check the manual Part II° for any changes.



Using other mixtures could invalidate the chiller warranty.

WATER QUALITY TABLE

	Minimum value	Maximum value
pH *	7	8
total hardness * °F	13	35
conductivity * μS/cm	200	350
alkalinity (HCO₃) * mg/L	200	300

* Considering water at temperature +20°C



WARNING for water coming out from the unit with temperature equal to or less than +5°C and in environments where the temperature is below 0°C, using water/glycol mixtures



WARNING lack of glycol in the system: If the unit is not used during the winter it can cause the freezing of water present in the system



IMPORTANT: Mixing water with glycol modifies the performance of the unit



The chiller cannot be used beyond the limits indicated in the nameplate.



NOTE FOR OIL CHILLERS

For ORA and ORW, use mineral oil-based hydraulic fluids based on the prevailing regulations with a viscosity of 22-68 mm²/s (cSt), using a filter with a filtering grade of 25μm.

PRELIMINARY OPERATIONS

- Chillers with a tank:
 - when the machine is off, fill the tank to the maximum level.
Use a clean container that is not contaminated by fluids or other additives than those set forth for filling. Do not mix different brands of products and/or additives.
- Vent the air from the pump body (where required):
 - when the machine is off, open the tap on the upper part of the pump body and release the air.
- Before starting the pump, check if the endorser turns freely.
Only use a screwdriver on centrifuge and peripheral pumps with intaglio located on the pump's fan side shaft and turn it in both directions to unblock it.
- To verify the correct direction of the triphase compressor rotation, observe the operation of the compressor that the aspiration pressure reduces and the unloading pressure increases. After a few minutes of operation counterclockwise, the compressor protection device works when the temperatures are too high. The technician will report a lack of chiller delivery.
- Check the direction the pump is rotating in for triphase models.
The correct rotation direction is marked by a tape arrow glued on the engine and the pump body.
- The control operation must be rapid, at most 15-20 seconds, provide tension and check the correct rotation.
If the rotation is not correct, after having removed the tension, invert two phases on the L1-L2-L3 power clamp in the control panel.
- Put the chiller under tension a few minutes to check:
 - the tank level and, if necessary, the feed (if present).
 - adjust the hydraulic by-pass (if present)

TURN ON AND TURN OFF

- To start the chiller, turn on the general switch: turn the switch to 1 (ON)
- To turn the chiller off, turn the general switch off: turn the switch to 0 (OFF)
- For some models, the remote ON-OFF command is available:
- once the chiller is turned off, this command does not stop the chiller but puts it in stand-by mode
- On the adjustment thermostat display, in addition to the temperature, alarm messages appear (if there is a problem, see the thermostat manual)
- If there is a problem, before turning it back on, remove the cause of the jam. (To restore several safety devices, rearm the safety device and restore the keyboard).
- These operations must be carried out by qualified staff, operators or maintenance technicians.
- It is forbidden to tamper with the safety devices.



Any unauthorized tampering invalidates the warranty and the manufacturer will accept no responsibility for any resulting damage.

CALIBRATION AND ADJUSTMENTS

- The chiller is already adjusted and calibrated when produced.
- The only adjustments that can be modified by the operator are:
The SET-POINT or work temperature adjustment value (within the limits, see the data label)
- The work pressure if the chiller is equipped with an adjustable hydraulic by-pass (within the limits, see the data label)

PLANT SHUT-DOWN



If there will be a plant shut-down in the winter, check the minimum ambient temperature that can be reached; if this is lower than the liquid freezing point inserted in the hydraulic circuit, unload and drain the circuit completely.

3.0 ORDINARY MAINTENANCE

WARNINGS



Before conducting any intervention, cut the chiller's tension.
To be safer, lock the general switch in the 0 (OFF) position with a lock (where applicable).

Be careful of high temperatures in the compressor head and compressor tubing (in copper that connects the compressor to the condenser) when the machine is off.

Be careful to the battery stabilisers since the aluminum stabilisers are very sharp.

At the end of the maintenance operations, reassemble the protective paneling.

All operations described in this section must be done by qualified staff.

The operators and maintenance people must use the DPI in accordance with the safety manager and prevailing legislation.

DPI=individual protection devices: gloves, helmet, goggles, accident prevention shoes, etc.



Periodic controls of the chiller must be done to check that it works properly.

In the table below, the controls to be done monthly and every 4 months are described.

ORDINARY MAINTENANCE		
COMPONENT	INTERVENTION	INTERVAL
One-time use air filters	Blow with air (if present)	1 MONTH
Regenerable air filters	Wash with water and degreasing agent (if present)	
Air condenser	Dust: blow with max 2 bar 0.2 MPa air (if necessary), possibly in the opposite direction as the aspiration	
Air condenser	Oil residue: wash with water and degreasing agent (if necessary)	
Coolant gas light	Check the presence of coolant gas: verify that when the compressor is on, when the plant is working, there are no air bubbles; if there are any bubbles, it could indicate a lack of gas in the circuit in which case keep the machine under control when it is on.	
Hydraulic circuit filters	Wash with water (if necessary)	
Tank liquid level	Feed if necessary: - turn off the machine and wait for all the fluid present in the circuit to go back to the tank - feed until (and not beyond) the MAX level indicated	
Air in the hydraulic circuit	Release air (only if the circuit is pressurised)	
Hydraulic circuit	Check for any losses (slow leaks)	
Fan and pump temperature	Check for abnormal temperatures	
Noise and vibrations	Check for any loose fastenings	

ORDINARY MAINTENANCE		
COMPONENT	INTERVENTION	INTERVAL
Control panel clamps	Check locks	4 MONTHS
Clamps in the compressor	Check locks	
Pressure switch connection	Check the connections	
Contactors	Check the contactors	
Fans	Check locks;	

ORDINARY MAINTENANCE		
Differential pressure switch	Check intervention and connections (if present)	1 YEAR
Flow switch	Check intervention and connections (if present)	
High pressure safety pressure switch	The high pressure safety pressure switch operation must be checked, simulating an increase in pressure and checking the intervention pressure of the equipment. If the pressure switch does not release at the calibrated pressure it is necessary to carry out the manual adjustment (on models equipped) and repeat the test to ensure the correct calibration. In models with fixed calibration, if the intervention of the pressure switch exceeds 10% of the original calibration pressure value, it is immediately required to replace the pressure switch.	

3.1 SPECIAL MAINTENANCE

The special maintenance is for official assistance centres.

For information and estimates, contact the manufacturer's technical assistance department (see contacts on the manual cover).

SPECIAL MAINTENANCE	
COMPONENT	INTERVENTION
Coolant gas feed	For the units loaded on R407C, two feeds are allowed. If another feed is needed, we suggest emptying the coolant circuit (when the machine is off), run the vacuum with the pump and reload the circuit with the amount indicated on the label.
Coolant gas humidity light	Following each intervention that requires the chiller circuit to be opened, check the colour of the humidity indicator. If the colour indicates humidity, replace the dehydrator filter. Make sure after the circuit is closed again to empty it with a pump for a sufficient period of time; to that end, check that the absolute pressure of at least 0.1 bar is attained using the manometer and check that, turning off the empty pump, this pressure doesn't increase (if it increases, it could indicate that the welding done was not done correctly). ATTENTION: the oils present in the coolant circuit are very hygroscopic so make sure during these operations to temporarily close all the tubes in contact with the air to avoid any prolonged contact.
Safety pressure relief valve	The safety pressure relief valve (where present) at least every 4 years from the date of initial start-up, should be replaced with a new valve with the same features and properly PED certified

3.2 COOLANT LEAKS CHECK

a) when the equipment coolant charge exceeds 3 kg it is compulsory to check the coolant leaks, pursuant to the European Regulation 842/2006

b) the equipment having more than 3 kg of coolant charge must have an equipment register where the various checks carried out are recorded.

3.3 SEARCHING FOR DEFECTS



All operations described in this section must be done by qualified staff.

The operators and maintenance people must use the DPI in accordance with the safety manager and prevailing legislation.

DPI=individual protection devices: gloves, helmet, goggles, accident prevention shoes, etc.

PROBLEM	POSSIBLE CAUSES	SUGGESTED INTERVENTION
I THE CHILLER DOES NOT START	1 THERE ARE NO EXTERNAL SIGNALS 2 INCORRECT CONNECTION WITH EXTERNAL SIGNALS 3 THE ANTI-RECIRCULATION TIMER IS ON	1 CHECK FOR EXTERNAL SIGNALS 2 CHECK CONNECTION WITH EXTERNAL SIGNALS 3 WAIT 5 MINUTES
II THE COMPRESSOR DOES NOT START	1 DEFECTIVE COMPRESSOR 2 THE POWER CIRCUIT IS OPEN 3 THE COMPRESSOR PROTECTION IS OPEN	1 CHECK THE WINDER PHASES WITH THE TESTER IF THEY ARE SHORT AND IF THE IMPEDANCE IS CORRECT AND THEN REPAIR/REPLACE THE ENGINE 2 CHECK THE POWER CIRCUIT 3 CHECK THE COMPRESSOR'S WORK CONDITIONS
III REPEATED STARTING AND STOPPING OF THE COMPRESSOR	1 DEFECTIVE COMPRESSOR 2 MINIMUM PRESSURE SWITCH INTERVENTION 3 DEFECTIVE COMPRESSOR CONTACTORS 4 INCORRECT THERMOSTAT CONFIGURATION 5 NO COOLANT	1 CHECK AND/OR REPLACE IT 2 SEE POINT V 3 CHECK AND/OR REPLACE IT 4 CHECK AND RESTORE THE ORIGINAL CONFIGURATION 5 SEE POINT VII
IV HIGH PRESSURE SWITCH INTERVENTION	1 DEFECTIVE PRESSURE SWITCH 2 AIR FILTER AND/OR BLOCKED CONDENSER 3 FAN(S) DO NOT WORK 4 BLOCKED COOLANT FILTER 5 EXCESSIVE COOLANT GAS LOAD	1 CHECK AND/OR REPLACE IT 2 CLEAN FILTER AND/OR CONDENSER 3 SEE POINT VI 4 CHECK IF THE LIQUID LIGHT INDICATES PLANT HUMIDITY OR IF THERE ARE BUBBLES IN THE LIQUID LIGHT DURING OPERATION OPERATIONS AND REPLACE THE GAS FILTER 5 REMOVE EXCESS COOLANT: IF THE CONDENSATION PRESSURE IS TOO HIGH AND THERE ARE NO OTHER PLANT PROBLEMS, be careful because zeotrope mixes like R407c do not allow the circuit to be partially released.
V MINIMUM PRESSURE SWITCH INTERVENTION	1 DEFECTIVE COMPRESSOR 2 NO GAS COOLANT 3 TAPS PARTIALLY CLOSED ON THE LIQUID LINE 4 BLOCKED COOLANT FILTER 5 BLOCKED THERMOSTAT VALVE 6 MISSING THERMAL LOAD 7 INSUFFICIENT LEVEL OF LIQUID IN THE TANK	1 CHECK AND/OR REPLACE IT 2 SEE POINT VII 3 CHECK AND OPEN THE TAPS COMPLETELY 4 CHECK AND/OR REPLACE IT. SEE POINT IV 5 CHECK IF THE MACHINE IS NOT COOL AND IF THE LOW PRESSURE SIDE HAS TOO LOW PRESSURE AND REPLACE IT 6 CHECK IF THE FLUID CIRCULATES IN THE EVAPORATOR 7 ADD LIQUID
VI THE FAN(S) DO NOT START	1 DEFECTIVE FAN CONTACTORS 2 THERMAL FAN(S) INTERVENTION 3 ENGINE OF DEFECTIVE FAN(S)	1 CHECK AND/OR REPLACE IT 2 CHECK FAN(S) ENGINE INSULATION 3 CHECK AND/OR REPLACE IT. SEE POINT II
VII NO COOLANT	1 LOSS FROM THE CHILLER CIRCUIT	1 PRESSURE THE CIRCUIT AT ABOUT 10 BAR, LOOK FOR LOSSES WITH A LEAK DETECTOR UNLOAD, REPAIR, VACUUM AND RELOAD.
VIII FROST THERMOSTAT	1 BLOCKED THERMOSTAT VALVE 2 NO GAS COOLANT	1 CHECK AND/OR REPLACE IT 2 SEE POINT VII
IX THE CHILLER WORKS CONTINUALLY WITHOUT ANY STOPS	1 NO GAS COOLANT 2 INCORRECT THERMOSTAT CONFIGURATION 3 EXCESSIVE THERMAL LOAD	1 SEE POINT VII 2 CHECK AND RESTORE THE ORIGINAL CONFIGURATION 3 REDUCE THE THERMAL LOAD
X THE CHILLER WORKS BUT DOES NOT COOL	1 NO GAS COOLANT 2 PRESENCE OF HUMIDITY IN THE CHILLER CIRCUIT 3 OPEN HOT GAS BY PASS VALVE	1 SEE POINT VII 2 UNLOAD, DRY THE CIRCUIT, REPLACE THE FILTER, EMPTY IT AND RELOAD IT. 3 CHECK AND/OR REPLACE IT
XI THE CHILLER PRODUCES ABNORMAL NOISES	1 NOISY COMPRESSOR 2 NOISY THERMOSTAT VALVE 3 VIBRATIONS FROM THE TUBES 4 NOISY BODY	1 SCROLL COMPRESSOR WITH INCORRECT ROTATION, CHECK THE ENGINE WINDER CONNECTION COMPLIES WITH THE ELECTRICAL CHART ON THE ENGINE AND INVERT THE PHASES SO THAT THE CORRECT ROTATION IS RESPECTED 2 CHECK AND/OR REPLACE IT 3 CHECK AND/OR SUPPORT THE TUBES 4 CHECK THE FASTENING LOCK

3.4 DISMANTLING AND DISPOSAL

To demolish a chiller, contact the collection centre.



If there are no specialised centres, do as follows:

- the coolant gas must be recovered by a chiller repairman and sent to an authorised collection centre.
- compressor oil is recovered and sent to an authorised collection centre.
- the remaining materials must be sent to a recycling centre.

ATTENTION



To demolish a chiller, a repairman must intervene.

Do not try to disassemble, cut or force the tubing of the chiller circuit.

Do not place the damaged or punctured tubes near open flames since the coolant gas vapours mixed with the compressor oil could catch on fire, producing toxic gas.

4.1 GENERAL WARRANTY CONDITIONS ON STULZ/COSMOTEC INDUSTRIAL COOLING PRODUCTS.

La Stulz S.p.A. guarantees that the product has no quality defects.

The products are not consumables and are exclusively used in the industrial and professional sector.

Warranty Period: 18 months from the shipping date from Stulz S.p.A. for all unit components.

In any case, the problems reported must be examined and all technical information requested by the Department must be supplied with the appropriate forms, to which the photographic documentation of the problem is attached. In particular, for components that are broken down, when they can be detected, the serial number/lot number and model number must be reported, indicating the device manufacturer in question.

Conditions of the Guarantee Validity

- 1) Circuits that do not require cooling powers over the power indicated in the label
- 2) Full respect for the regulations, recommendations and information in this use and maintenance manual
- 3) Client demonstrating in document form the regular execution of preventative maintenance by adequately trained staff

Conditions of the Guarantee Non-Validity

- 1) Change or modification of a unit structure or circuits
- 2) Introduction of gases in the coolant circuit in the amount or a quality different from those listed on the label
- 3) Operation of the unit in areas with acidic or corrosive atmospheres
- 4) Application of products if there are shocks, handling and temperature outside the label value
- 5) Irregularities of payments for previous supplies

The warranty will also expire for applications in which the amount/capacity of fluid for the condensing part and evaporating part are not guaranteed and shown.

If there is corrosion or erosion, the client must prove the purity of the fluids, air or water, used by the cooling system. The plant or condensation water is considered pure if the parameters we indicated in the use and maintenance manual are respected.

For products intended for special uses or for a use other than their standard application, for which there is no experience from specific applications, like those requested by the client and for which the client has not paid for the study, development and tests, the information provided by the manufacturer regarding the product's use and characteristics are merely for information only and are not binding.

For products with a special code, not present in the commercial catalogue, the replacement part components must be purchased along with the product since the manufacturer does not guarantee that it will be available if necessary.

Warranty Conditions

In the warranty period, the components and/or machines are produced under "Warranty pending control" except for consumables (for example: mechanical seals for hydraulic pumps, transmission belts, filters, etc) for which Stulz S.p.A. does not grant any warranties.

- For each defective part, during the warranty period, Stulz S.p.A. will, at its sole discretion, repair or replace it at its plant or at the company if authorised. If the warranty is granted, Stulz S.p.A. will solely bear all costs for the defective components, the manpower to make the repair and the transportation costs to deliver the unit or components repaired/replaced to the client.
- If the Client expressly requests an intervention at its offices, Stulz S.p.A. will not be the responsibility of the staff transfer costs that will be billed based on the Stulz S.p.A. rates set forth in the request document, which can be viewed on the "Technical Assistance" page at www.stulz.it.
- If agreed with Stulz S.p.A., the replacement part will be sent at the expense of the client. Stulz S.p.A. will issue the sales order FOB. The component declared to be defective must be returned to Stulz S.p.A. within 40 days from receipt of the replacement part with the client transporting the part. In the case where, analyzing the delivery, the client is not responsible for the defect, Stulz S.p.A. will credit the previously billed replacement part. In the case where the component is not defective, it will be kept definitely by Stulz S.p.A. and will be charged minus 10% of its value and with a minimum expense of €25.

In the case where, following the analyses conducted by Stulz S.p.A. or by the subject appointed, the client is responsible for the defect, all costs incurred, including any charges by suppliers for component controls and repairs including any shipping costs will be billed to the Client.

Stulz S.p.A. will not be liable for all expenses that occur, such as, for example, the removal, installation and handling of the unit and the material shipping costs to Stulz S.p.A. All expenses not covered by Stulz S.p.A. but incurred by it will be charged to the Client.

Stulz S.p.A. provides a warranty period equal to six months from which the components were replaced and repaired.

At the end of the warranty period, the products repaired and replaced do not modify the start and end time for the warranty.

Stulz S.p.A. applies the aforementioned conditions for units that breakdown at start up.

4.2 STULZ / COSMOTEC PRODUCT DELIVERY TO STULZ S.P.A.

The delivery to Stulz S.p.A. must be previously authorised by assigning an authorization code to the delivery to be made to the transportation document.

The authorization code for the delivery is requested from Stulz S.p.A., exclusively by direct clients, by filling out the "Delivery Request/Technical Assistance" form in detail.

Remember that:

- The transportation costs for returned merchandise is at the client's expense. Stulz S.p.A. will not pick up material delivered with the transportation costs at its own expense.
- The material must be delivered with transportation documents on which the delivery authorization code is cited. In the case where a courier is used that handles the pick-ups through delivery slips, insert the transportation document in the package or affix it to the package.
- The merchandise acceptance warehouse will not accept material without an authorization code for the delivery cited on the transportation document or in a clear manner on the package.
- The delivery credited for the incorrect order or lack of sale by the client are subject to economic deductions to cover the control, lay out and administrative costs incurred by Stulz S.p.A. that can vary based on the conditions of the merchandise delivered. The minimum deduction amount is equal to 15% of the asset value.
- Stulz S.p.A. will charge the client €5- as the delivered unit control costs for repairs outside of the warranty if the repair estimate is rejected. At the client's request, Stulz S.p.A. will dispose of the unrepaired delivery, charging €25. When it receives this request, Stulz S.p.A. will send an authorization form for the disposal that the client will fill out and sign.

Contacts:

STULZ SPA
Via Torricelli, 3
37067 Valeggio s/Mincio – VR – ITALY

www.stulz.it

info@stulz.it

aftersales@stulz.it

Tel. – Switchboard 0039 045 6331650

Tel. – Technical Assistance 0039 045 6331615

Fax 0039 045 6331635